

GLOBALLY RAISING THE STANDARDS OF FOOD THROUGH THE ART OF SLICING

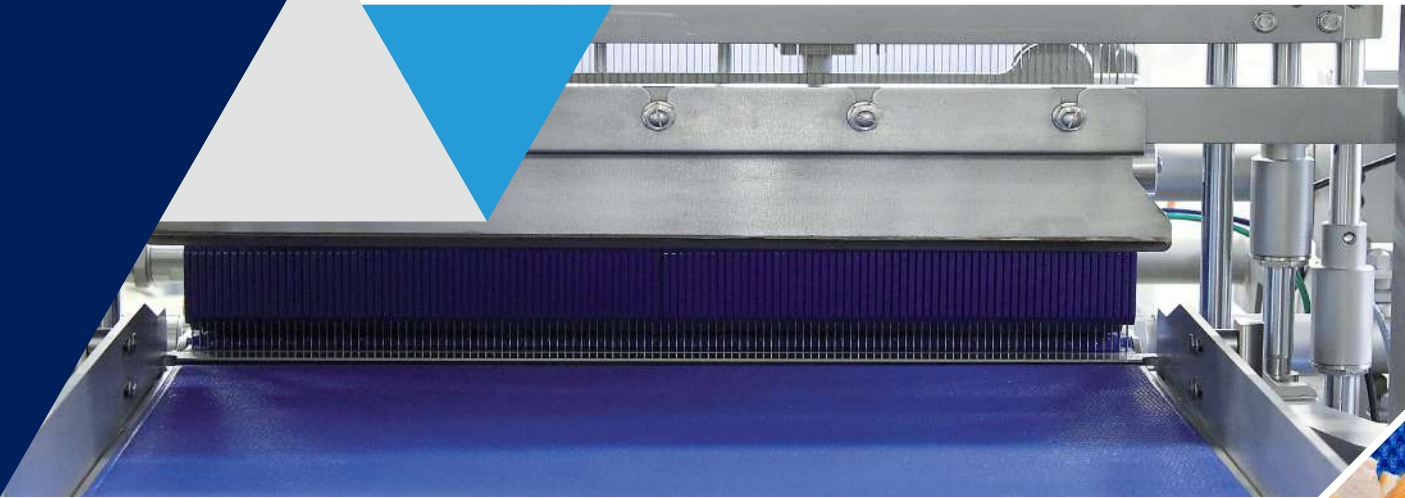

NSA XC

Vertical Slicing machine
for fresh and cooked meat



AFFETTATRICE VERTICALE PER CARNE FRESCA O COTTA



NSA XC

Ottieni tagli 2D a strisce o cubi, completamente in linea. Precisione di taglio estrema e alta produttività, per tagli 2D in strisce o cubi, come parte di un processo totalmente in linea con una resa estremamente alta.

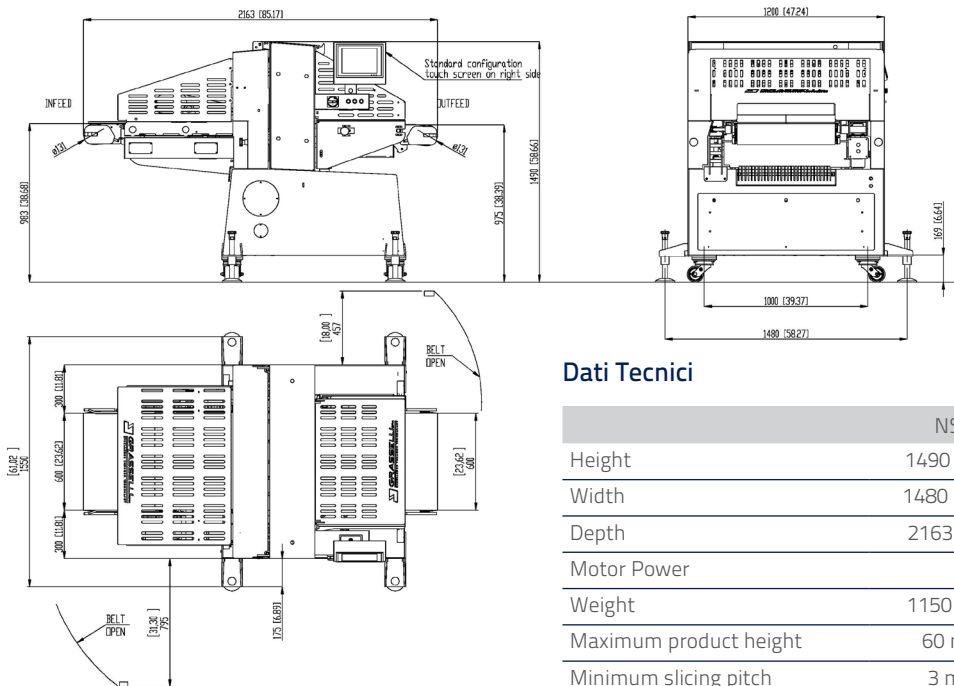

Dati Tecnici

	NSA 600 XC	NSA 1000 XC
Height	1490 mm / 58.66"	1500 mm / 59.05"
Width	1480 mm / 58.27"	1950 mm / 76.77"
Depth	2163 mm / 85.17"	2178 mm / 85.74"
Motor Power	5 Kw	5 Kw
Weight	1150 Kg / 2535 lb	1300 Kg / 2866 lb
Maximum product height	60 mm / 2.36"	60 mm / 2.36"
Minimum slicing pitch	3 mm / 0.12"	5 mm / 0.2"
Operator control circuit	24V	24V
Maximum working width	610 mm / 24.02"	1000 mm / 39.37"
Maximum 3D cutting width	5 cm / 1.97"	5 cm / 1.97"

**1. Soluzione totalmente in linea, anche direttamente dal forno**

NSA XC permette di tagliare un flusso continuo di prodotto caldo o fresco/rinfrescato completamente in linea senza necessità di manipolazione da parte dell'operatore.

**2. Produttività e rendimento incredibili**

Con un piano di lavoro da 600mm, NSA XC offre elevata produttività fino a 4 tonnellate all'ora e fino al 97% di resa.

**3. Qualità di taglio superiore**

Grazie alla tecnologia di taglio "Gentile" tipica delle macchine Grasselli, la nuova NSA XC può offrire una qualità di taglio superiore senza preventiva preparazione (ad esempio raffreddamento, formatura ecc..).

**4. Preparazione veloce per la sanificazione senza rischio batterico**

NSA XC è stata sviluppata per ottenere una completa sanificazione sia interna che esterna (versione B). Tutte le parti che operano a contatto con gli alimenti sono facilmente estraibili per una facile sanificazione senza la necessità di alcun utensile.

**5. Flessibilità**

Grazie all'interfaccia user-friendly, NSA XC è davvero flessibile nell'impostazione delle ricette e nelle configurazioni della macchina, includendo la possibilità di utilizzarla come nastro passante quando non è in azione per evitare i fermi macchina dovuti allo spostamento della macchina fuori linea.

**6. Assistenza e Statistiche in tempo reale**

Grazie alla connessione ad Internet, NSA XC può generare statistiche della produzione in tempo reale direttamente sul tuo PC e fornire assistenza live per ridurre i fermi macchina.

**7. Risparmia tempo nelle regolazioni Meccaniche**

L'opzione di cambio rapido lame minimizza il tempo necessario per cambiare il set di taglio.



VERTICAL SLICING MACHINE FOR FRESH AND COOKED MEAT



NSA XC

Obtain 2D cuts in strips or cubes, completely in-line.
Extreme cutting precision and high productivity, for 2D cuts in strips or cubes, as part of a fully in-line process with an extremely high yield.

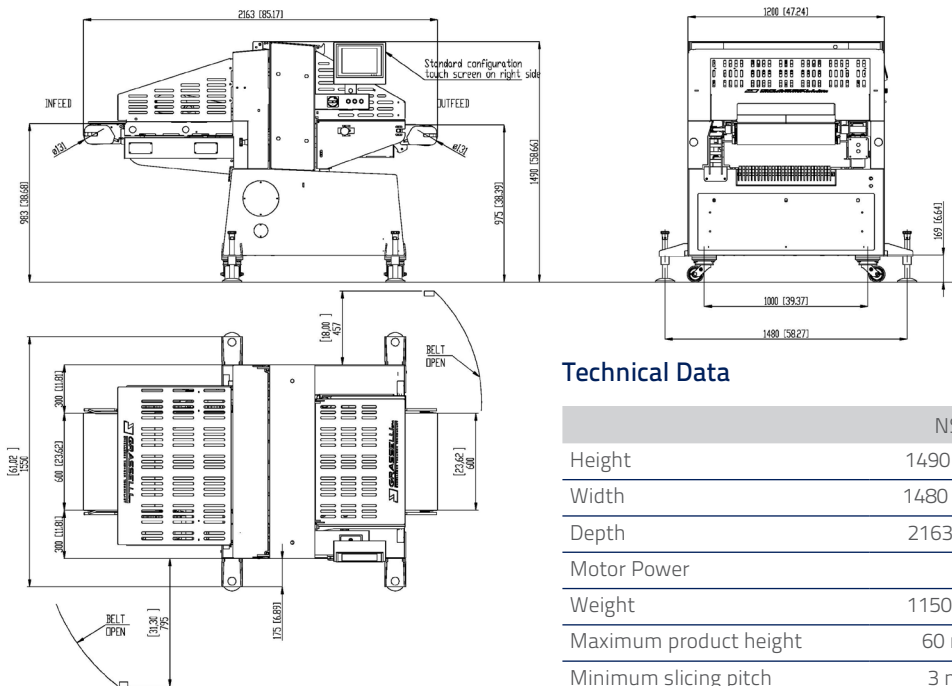

Technical Data

	NSA 600 XC	NSA 1000 XC
Height	1490 mm / 58.66"	1500 mm / 59.05"
Width	1480 mm / 58.27"	1950 mm / 76.77"
Depth	2163 mm / 85.17"	2178 mm / 85.74"
Motor Power	5 Kw	5 Kw
Weight	1150 Kg / 2535 lb	1300 Kg / 2866 lb
Maximum product height	60 mm / 2.36"	60 mm / 2.36"
Minimum slicing pitch	3 mm / 0.12"	5 mm / 0.2"
Operator control circuit	24V	24V
Maximum working width	610 mm / 24.02"	1000 mm / 39.37"
Maximum 3D cutting width	5 cm / 1.97"	5 cm / 1.97"



1. Complete in-line solution, even straight from the oven

NSA XC allows to slice a continuous flow of hot or fresh/chilled product completely in line with no need of handling by the operator.



2. Incredible productivity and yield

With a 600 working width, NSA XC delivers superior productivity up to 4 tons/hour and up to 97% yield.



3. Superior slicing quality

Thanks to the gentle slicing technology typical of the Grasselli machines, NSA XC can deliver superior slicing quality with no need of previous preparations (e.g. chilling, forming, etc.).



4. Quick preparation for sanitation and no bacterial risks

NSA XC is designed to get a thorough sanitation on both external surfaces and internal compartments (B version). All the components working in the food area are easily removable for sanitation without the use of any tools.



5. Flexibility

Thanks to a user-friendly interface, NSA XC is very flexible in the definition of recipes and machine configurations, including the possibility to use it as a pass-through belt when not in operation to avoid the down-time of moving the machine out of the line.



6. Live stats and assistance

Thanks to the Internet connection, NSA XC can deliver live production statistics directly on your PC and provide you with live assistance to reduce machine downtimes.



7. Save time on mechanical adjustments

The option of the quick blade change minimizes the time needed to change the slicing set.





NSA XC

Получите 2D-ломтики или кубики, полностью в составе линии.

Предельная точность резки и высокая производительность для 2D-резки ломтиков или кубиков, как часть полностью осуществляемого на линии процесса с чрезвычайно высоким выходом

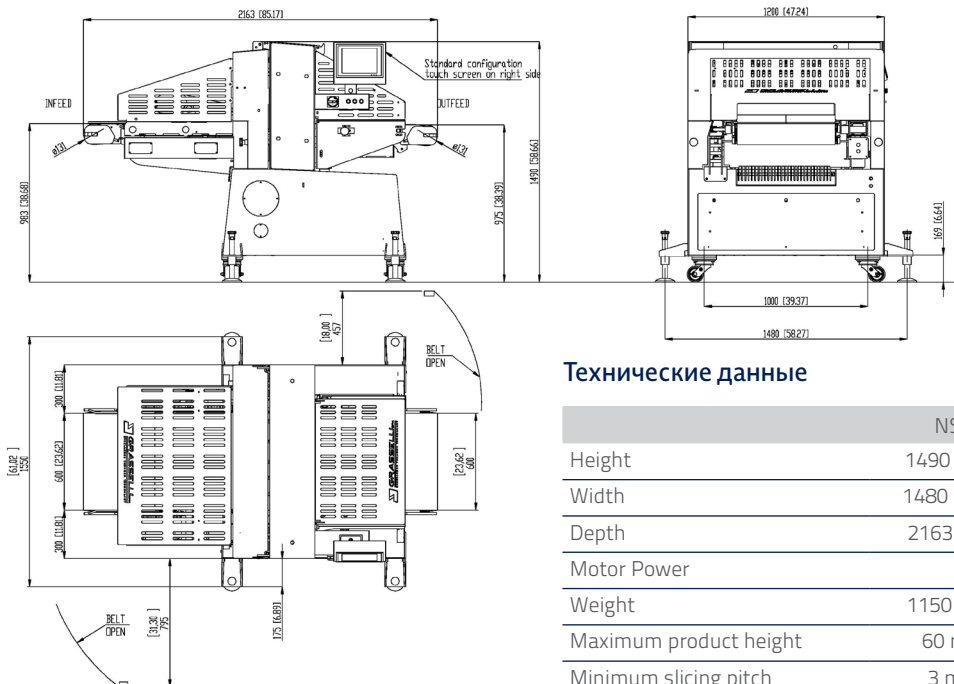

Технические данные

	NSA 600 XC	NSA 1000 XC
Height	1490 mm / 58.66"	1500 mm / 59.05"
Width	1480 mm / 58.27"	1950 mm / 76.77"
Depth	2163 mm / 85.17"	2178 mm / 85.74"
Motor Power	5 Kw	5 Kw
Weight	1150 Kg / 2535 lb	1300 Kg / 2866 lb
Maximum product height	60 mm / 2.36"	60 mm / 2.36"
Minimum slicing pitch	3 mm / 0.12"	5 mm / 0.2"
Operator control circuit	24V	24V
Maximum working width	610 mm / 24.02"	1000 mm / 39.37"
Maximum 3D cutting width	5 cm / 1.97"	5 cm / 1.97"

ВЕРТИКАЛЬНАЯ ЛОМТЕРЕЗКА ДЛЯ СВЕЖЕГО ИЛИ ВАРЕНОГО МЯСА



1. Решение для использования полностью на линии, в том числе с подачей продукта прямо из печи

NSA XC позволяет вести резку непрерывного потока горячего или свежего/охлажденного продукта полностью на линии без необходимости каких-либо действий со стороны оператора.



2. Невероятная производительность и выход продукции

Благодаря столу диаметром 600 мм NSA XC обеспечивает высокую производительность до 4 тонн в час и выход продукции до 97 %.



3. Превосходное качество резки
Благодаря “щадящей” технологии резки, характерной для станков Grasselli, новая NSA XC может обеспечивать превосходное качество резки без предварительной подготовки (например, охлаждения, формовки и т.д.).



4. Быстрая подготовка к дезинфекции без риска бактериального роста

NSA XC разработана для достижения полной дезинфекции как изнутри, так и снаружи (исполнение В). Все части, контактирующие с пищевыми продуктами, легко снимаются для обеспечения легкой дезинфекции без использования каких-либо инструментов.



5. Гибкость

Благодаря удобному интерфейсу NSA XC характеризуется подлинной гибкостью задания рецептов и конфигураций машины, включая возможность использовать ее в качестве проходного ленточного транспортера, когда она не задействована в процессе производства, во избежание простоев вследствие вывода машины из линии.



6. Поддержка и статистика в режиме реального времени

Благодаря подключению к Интернету NSA XC может в реальном времени генерировать данные по статистике производства прямо на вашем компьютере, а также в режиме реального времени обеспечивать доступ к технической поддержке для сокращения времени простоя машины.



7. Экономия времени на механическую регулировку

Опция быстрой смены ножей сводит к минимуму время, необходимое для замены режущего комплекта.



Follow Us

CORTADORA VERTICAL PARA CARNE FRESCA O COCIDA



NSA XC

Obtenga cortes 2D en tiras o cubos, completamente en línea. Extrema precisión de corte y alta productividad, para cortes 2D en tiras o cubos, como parte de un proceso totalmente en línea con un rendimiento extremadamente alto.

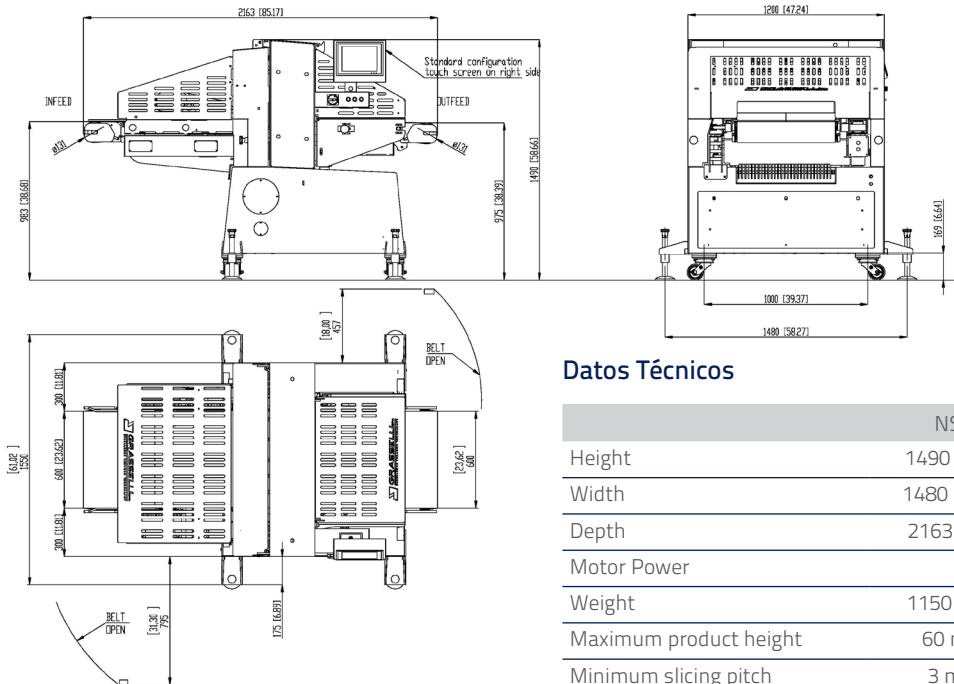

Datos Técnicos

	NSA 600 XC	NSA 1000 XC
Height	1490 mm / 58.66"	1500 mm / 59.05"
Width	1480 mm / 58.27"	1950 mm / 76.77"
Depth	2163 mm / 85.17"	2178 mm / 85.74"
Motor Power	5 Kw	5 Kw
Weight	1150 Kg / 2535 lb	1300 Kg / 2866 lb
Maximum product height	60 mm / 2.36"	60 mm / 2.36"
Minimum slicing pitch	3 mm / 0.12"	5 mm / 0.2"
Operator control circuit	24V	24V
Maximum working width	610 mm / 24.02"	1000 mm / 39.37"
Maximum 3D cutting width	5 cm / 1.97"	5 cm / 1.97"

**1. Solución totalmente en línea, incluso directamente desde el horno**

La NSA XC permite cortar un flujo continuo de producto caliente o fresco/refrigerado completamente en línea sin necesidad de manipulación por parte del operario.

**2. Increíble productividad y rendimiento**

Con una mesa de 600 mm, la NSA XC ofrece una alta productividad de hasta 4 toneladas por hora y un rendimiento de hasta el 97%.

**3. Calidad de corte superior**

Gracias a la tecnología de corte «suave» típica de las máquinas Grasselli, la nueva NSA XC puede ofrecer una calidad de corte superior sin necesidad de preparación previa (por ejemplo, enfriamiento, conformación, etc.).

**4. Preparación rápida para la desinfección sin riesgo bacteriano**

La NSA XC se ha desarrollado para conseguir una desinfección completa tanto a nivel interno como externo (versión B). Todas las piezas que entran en contacto con los alimentos se pueden extraer fácilmente para facilitar la desinfección sin necesidad de herramientas.

**5. Flexibilidad**

Gracias a su sencilla interfaz, la NSA XC es muy flexible a la hora de establecer las recetas y las configuraciones de la máquina, incluida la posibilidad de utilizarla como cinta de paso cuando no está en funcionamiento para evitar el tiempo de inactividad de la máquina debido a su desplazamiento fuera de línea.

**6. Asistencia y estadísticas en tiempo real**

Gracias a su conexión a Internet, la NSA XC puede generar estadísticas de producción en tiempo real directamente en su PC y proporcionar asistencia en directo para reducir el tiempo de inactividad.

**7. Ahorre tiempo en los ajustes mecánicos**

La opción de cambio rápido de cuchillas minimiza el tiempo necesario para cambiar el kit de corte.



VERTIKALSCHNEIDER FÜR FRISCHE UND GEGARTE PRODUKTE



NSA XC

Schneiden Sie 2-dimensional im „Inline-Prozess“ Streifen oder Würfel. Hervorragende Schnittqualität und hohe Produktionsleistung bei 2D-Schnitten für die Streifen- oder Würfelproduktion. Das alles vollautomatisch im Inline-Prozess bei extrem hoher Leistung.

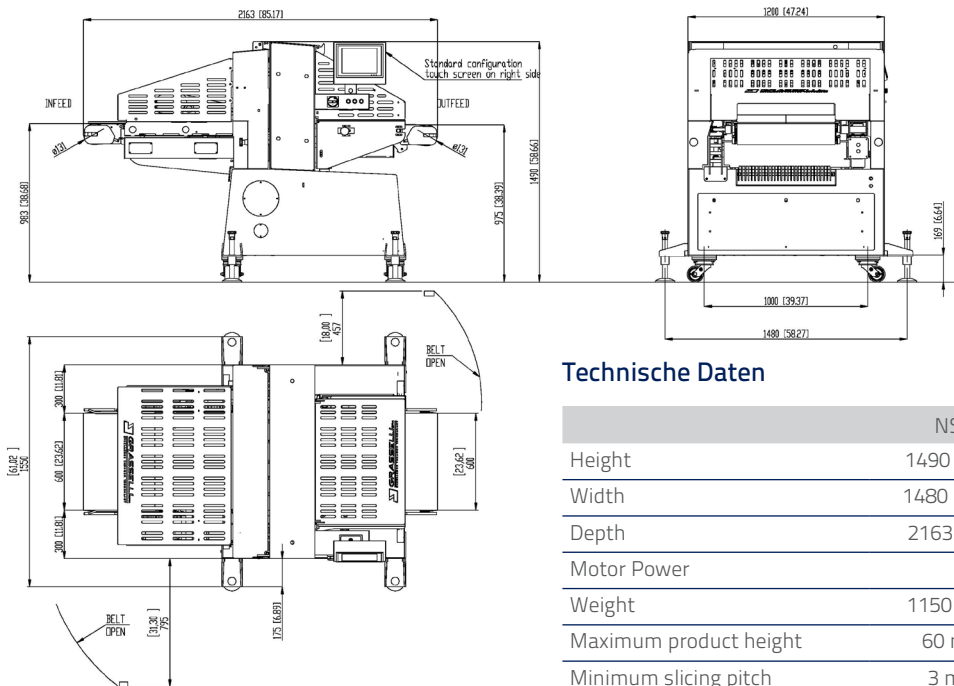

Technische Daten

	NSA 600 XC	NSA 1000 XC
Height	1490 mm / 58.66"	1500 mm / 59.05"
Width	1480 mm / 58.27"	1950 mm / 76.77"
Depth	2163 mm / 85.17"	2178 mm / 85.74"
Motor Power	5 Kw	5 Kw
Weight	1150 Kg / 2535 lb	1300 Kg / 2866 lb
Maximum product height	60 mm / 2.36"	60 mm / 2.36"
Minimum slicing pitch	3 mm / 0.12"	5 mm / 0.2"
Operator control circuit	24V	24V
Maximum working width	610 mm / 24.02"	1000 mm / 39.37"
Maximum 3D cutting width	5 cm / 1.97"	5 cm / 1.97"

**1. Eine vollautomatische Lösung!
Auch für die Anwendung direkt hinter dem Ofen**

NSA XC ermöglicht das Schneiden eines kontinuierlichen Stroms heißer oder frischer/gekühlter Produkte in der Linie. Ganz ohne Personaleinsatz.

**2. Unglaubliche Produktionsleistung**

Mit einer 600er (Gurtbreite) bietet die NSA XC eine hohe Produktionsleistung von bis zu 4 Tonnen pro Stunde.

**3. Hervorragende Schnittqualität**

Dank der für Grasselli-Maschinen typischen Gentile-Schneidtechnologie bietet die neue NSA XC eine überragende Schnittqualität ohne vorherige Vorbereitung (z. B. Kühlen, Formen usw.).

**4. Schnelle Reinigung / Zwischenreinigung bei Bedarf.****Kein mikrobielles Risiko**

NSA XC wurde so entwickelt, dass die Anlage sowohl von außen als auch von innen gereinigt und desinfiziert werden kann (Version B). Alle Teile, die mit Lebensmitteln in Berührung kommen, sind leicht abnehmbar und können so ohne den Einsatz von Werkzeugen entnommen und gereinigt werden.

**5. Flexibilität**

Dank seiner benutzerfreundlichen Schnittstelle ist die NSA XC sehr flexibel bei der Einrichtung von produktspezifischen Programmen und Maschinenkonfigurationen. Des Weiteren kann die Anlage, wenn nicht geschnitten werden soll, als Durchlauf dienen und muss nicht aus der Line genommen werden.

**6. Unterstützung und Statistiken in Echtzeit**

Dank seiner Internetverbindung kann NSA XC Produktionsstatistiken in Echtzeit direkt auf Ihrem PC erstellen und Live-Support bieten, um Ausfallzeiten zu reduzieren.

**7. Sparen Sie Zeit bei mechanischen Einstellungen**

Mit unseren optionalen Schnellwechselwerkzeugen können Schneidsätze im Handumdrehen gewechselt werden.



TRANCHEUR VERTICAL POUR LA VIANDE FRAÎCHE OU CUITE



NSA XC

Obtenez des coupes 2D en bandes ou en cut complètement alignées.

Précision de coupe extrême et productivité é pour des coupes 2D en bandes ou en cubes, cadre d'un processus entièrement en ligne a rendement extrêmement élevé.

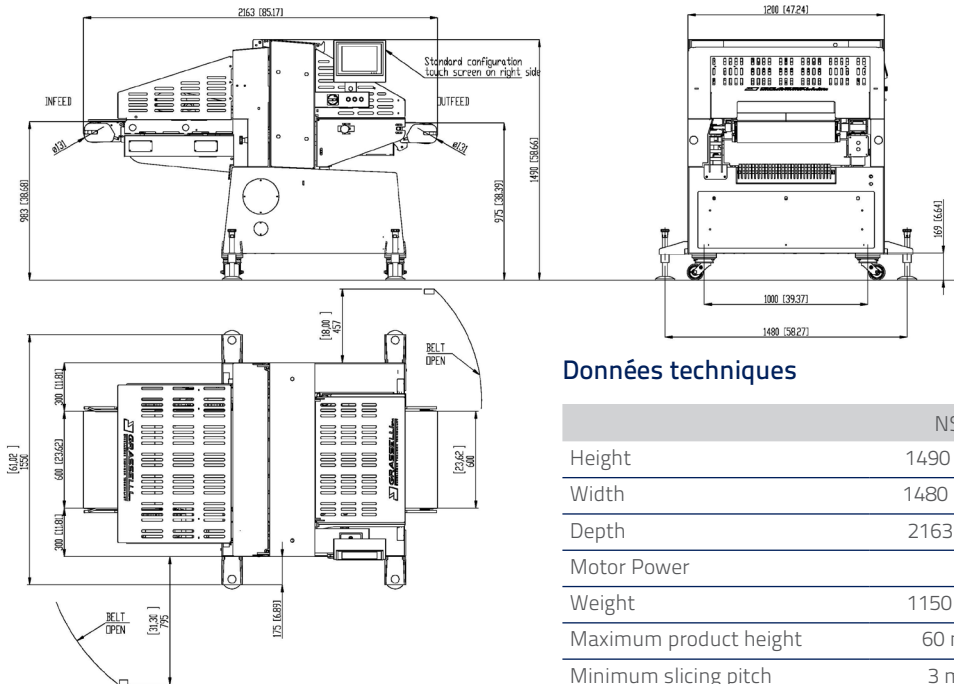

Données techniques

	NSA 600 XC	NSA 1000 XC
Height	1490 mm / 58.66"	1500 mm / 59.05"
Width	1480 mm / 58.27"	1950 mm / 76.77"
Depth	2163 mm / 85.17"	2178 mm / 85.74"
Motor Power	5 Kw	5 Kw
Weight	1150 Kg / 2535 lb	1300 Kg / 2866 lb
Maximum product height	60 mm / 2.36"	60 mm / 2.36"
Minimum slicing pitch	3 mm / 0.12"	5 mm / 0.2"
Operator control circuit	24V	24V
Maximum working width	610 mm / 24.02"	1000 mm / 39.37"
Maximum 3D cutting width	5 cm / 1.97"	5 cm / 1.97"

**1. Solution totalement en ligne, même à la sortie du four**

La NSA XC permet de couper complètement en ligne un flux continu de produits chauds ou frais/réfrigérés sans qu'il soit nécessaire de faire appel à un opérateur.

**2. Une productivité et un rendement incroyables**

Avec une table de 600 mm, la NSA XC offre une productivité élevée allant jusqu'à 4 tonnes par heure et un rendement de 97 %.

**3. Qualité de coupe supérieure**

Grâce à la technologie de coupe « Gentile » typique des machines Grasselli, la nouvelle NSA XC peut offrir une qualité de coupe supérieure sans préparation préalable (par exemple, refroidissement, formage, etc.).

**4. Préparation rapide pour l'assainissement sans risque bactérien**

La NSA XC a été développée afin de réaliser une désinfection complète, tant en interne qu'en externe (version B). Toutes les parties qui entrent en contact avec les aliments sont facilement démontables pour une désinfection aisée, sans avoir besoin d'outils.

**5. Flexibilité**

Grâce à son interface conviviale, la NSA XC est très flexible dans le réglage des recettes et des configurations de la machine, y compris la possibilité de l'utiliser comme ruban de transport passant lorsqu'elle n'est pas en action afin d'éviter les temps d'arrêt de la machine dus à la mise hors ligne de la machine.

**6. Assistance et statistiques en temps réel**

Grâce à sa connexion Internet, la NSA XC peut générer des statistiques de production en temps réel directement sur votre PC et fournir une assistance en direct pour réduire les temps d'arrêt.

**7. Gagnez du temps sur les réglages mécaniques**

L'option de changement rapide des lames réduit au minimum le temps nécessaire pour changer le jeu de coupe.



CORTADOR VERTICAL PARA CARNE FRESCA OU COZINHADA



NSA XC

Obter cortes 2D em tiras ou cubos, completamente em linha.

Extrema precisão de corte e alta produtividade para cortes 2D em tiras ou cubos, como parte de um processo totalmente em linha com um rendimento extremamente elevado.

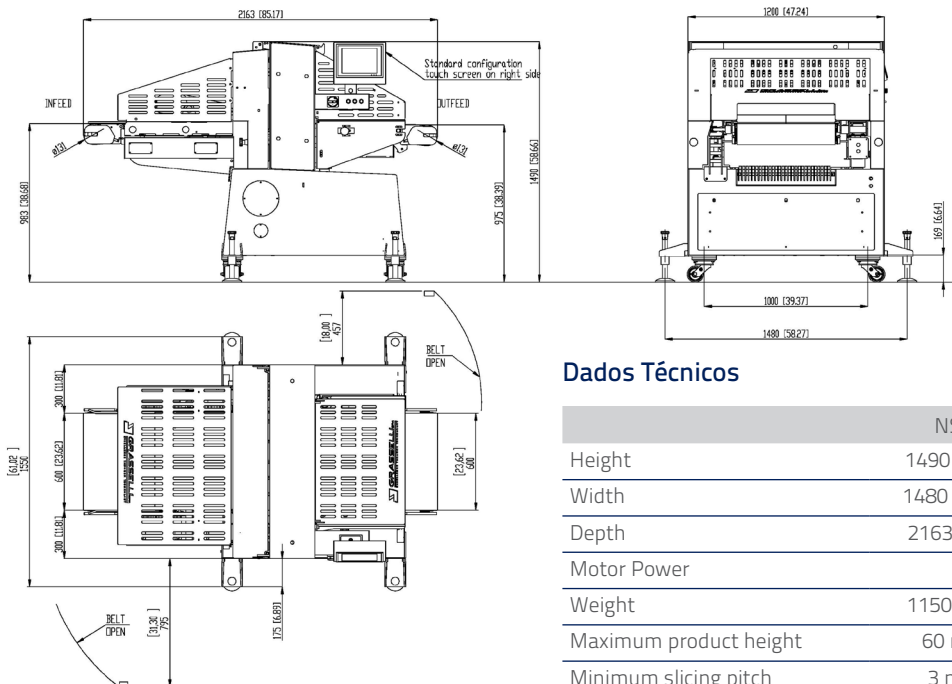

Dados Técnicos

	NSA 600 XC	NSA 1000 XC
Height	1490 mm / 58.66"	1500 mm / 59.05"
Width	1480 mm / 58.27"	1950 mm / 76.77"
Depth	2163 mm / 85.17"	2178 mm / 85.74"
Motor Power	5 Kw	5 Kw
Weight	1150 Kg / 2535 lb	1300 Kg / 2866 lb
Maximum product height	60 mm / 2.36"	60 mm / 2.36"
Minimum slicing pitch	3 mm / 0.12"	5 mm / 0.2"
Operator control circuit	24V	24V
Maximum working width	610 mm / 24.02"	1000 mm / 39.37"
Maximum 3D cutting width	5 cm / 1.97"	5 cm / 1.97"

**1. Solução totalmente em linha, mesmo diretamente do forno**

O NSA XC permite um fluxo contínuo de produto quente ou fresco/refrigerado a ser cortado completamente em linha sem a necessidade de manipulação por parte do operador.

**2. Produtividade e resultados incríveis**

Com uma bancada de trabalho de 600 mm, a NSA XC oferece uma produtividade elevada de até 4 toneladas por hora e uma produção de até 97%.

**3. Qualidade de corte superior**

Graças à tecnologia de corte 'Gentile' típica das máquinas Grasselli, o novo NSA XC pode oferecer uma qualidade de corte superior sem preparação prévia (por exemplo, arrefecimento, moldagem, etc.).

**4. Preparação rápida para a higienização sem risco bacteriano**

O NSA XC foi desenvolvido para conseguir uma higienização completa tanto interna como externamente (versão B). Todas as peças de contacto alimentar são facilmente removíveis para uma fácil higienização sem necessidade de quaisquer utensílios.

**5. Flexibilidade**

Graças à sua interface de fácil utilização, a NSA XC é muito flexível na configuração de receitas e configurações de máquinas, incluindo a possibilidade de a utilizar como tapete de passagem quando não está em ação para evitar a paragem da máquina devido à deslocação da máquina para fora de linha.

**6. Apoio e Estatísticas em Tempo Real**

Graças à sua ligação à Internet, a NSA XC pode gerar estatísticas de produção em tempo real diretamente no seu PC e fornecer apoio em direto para reduzir o tempo de inatividade.

**7. Poupe tempo nos ajustes Mecânicos**

A opção de troca rápida da lâmina minimiza o tempo necessário para trocar o conjunto de corte.



鲜肉或熟肉纵向切片机



NSA XC

在生产线上实现条状或方块状二维切片。
极高的切割精度和高生产效率，用于条状或块状二维切片，作为生产线全流程的一部分，具有极高的产量。

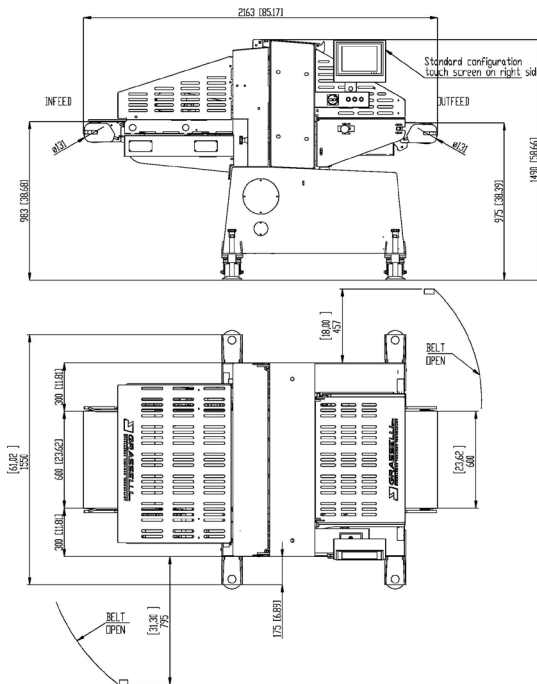

技术参数

	NSA 600 XC	NSA 1000 XC
Height	1490 mm / 58.66"	1500 mm / 59.05"
Width	1480 mm / 58.27"	1950 mm / 76.77"
Depth	2163 mm / 85.17"	2178 mm / 85.74"
Motor Power	5 Kw	5 Kw
Weight	1150 Kg / 2535 lb	1300 Kg / 2866 lb
Maximum product height	60 mm / 2.36"	60 mm / 2.36"
Minimum slicing pitch	3 mm / 0.12"	5 mm / 0.2"
Operator control circuit	24V	24V
Maximum working width	610 mm / 24.02"	1000 mm / 39.37"
Maximum 3D cutting width	5 cm / 1.97"	5 cm / 1.97"



1. 完全生产线方案, 也直接来自烤箱

NSA XC 切片机可以在生产线上连续切割热加工产品或新鲜/冷却的产品, 无需操作员进行操作。



2. 难以置信的生产效率和产量

NSA XC 切片机具有 600 毫米的工作台, 生产效率高达每小时 4 吨, 产量高达 97%。



3. 极高的切割质量

得益于 Grasselli 机器典型的“轻柔”切割技术, 新型 NSA XC 切片机无需事先准备 (例如冷却、成型等) 即可提供极高的切割质量。



4. 快速实现无细菌风险的卫生条件

NSA XC 切片机的开发旨在实现内外部完全消毒 (B 型号)。与食物接触的零件易于拆卸, 便于消毒, 无需任何工具。



5. 灵活性

得益于用户友好界面, NSA XC 切片机在设置配方和配置机器方面非常灵活, 在不运行时可以作为通过传送带, 以避免机器移出生产线造成机器停机。



6. 实时服务和数据统计

得益于互联网连接, NSA XC 切片机能够在个人电脑上直接、实时生成生产统计数据, 提供实时服务, 以减少机器停机导致数据丢失的风险。



7. 节省机械调整时间

快速刀具更换选项可最大限度地缩短整套刀具的更换时间。



