

KSL400

1) Pneumatic connection feeding point:

- Pneumatic power supply 6±10 bar
- Max air consumption at 6 bar = 15 litres/min
- 150 litres/min with air cleaning system

2) Electric connection feeding point:

- Max absorption (400V) = 11,2 A
- Three-phases power supply at 400 V or 480 V (3P+G)
- Frequency = 50±60 Hz
- Cable 4x2,5mm² lenght 6,5m

Whit support 30369ASSY machine is higher 27 mm

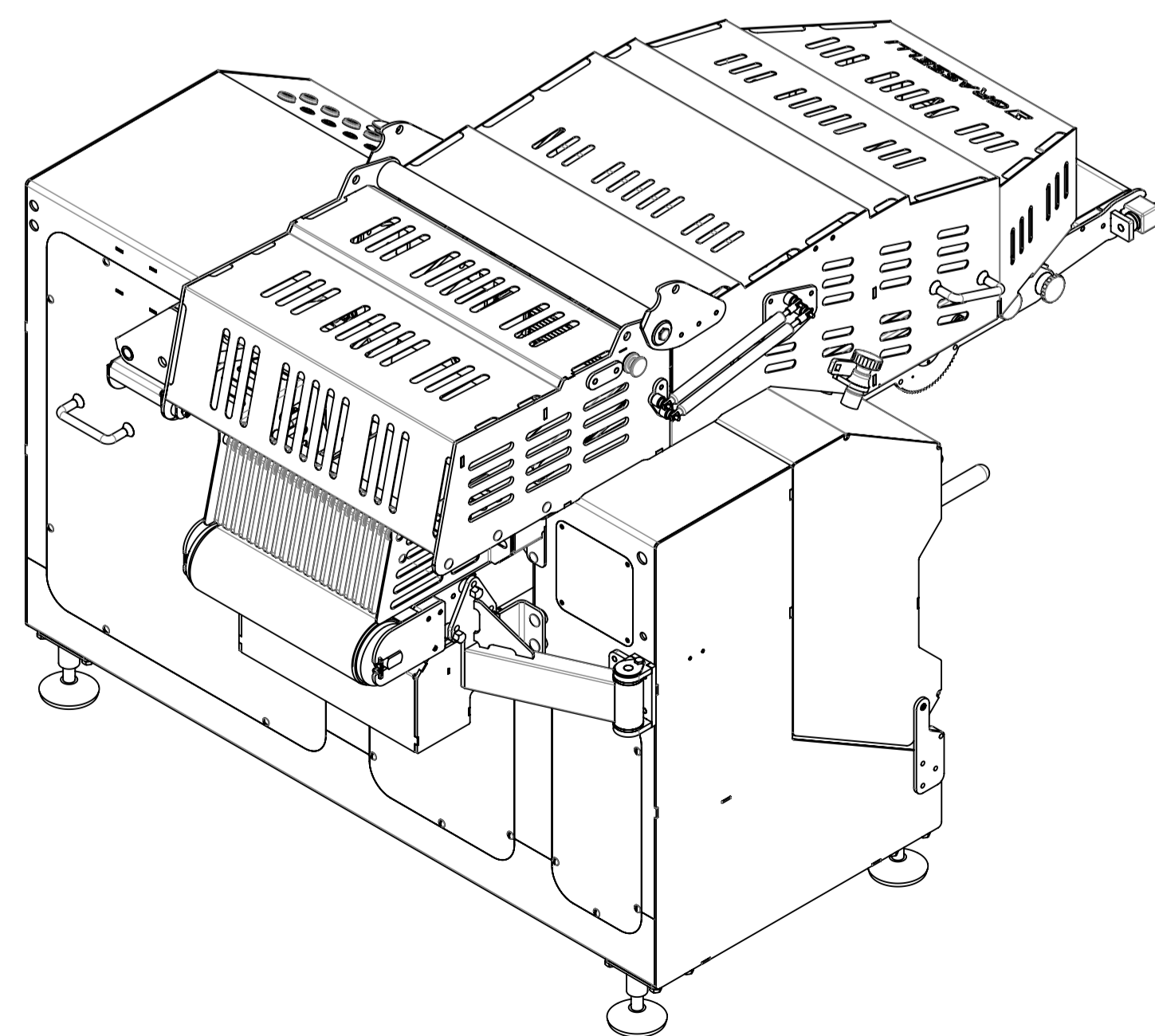
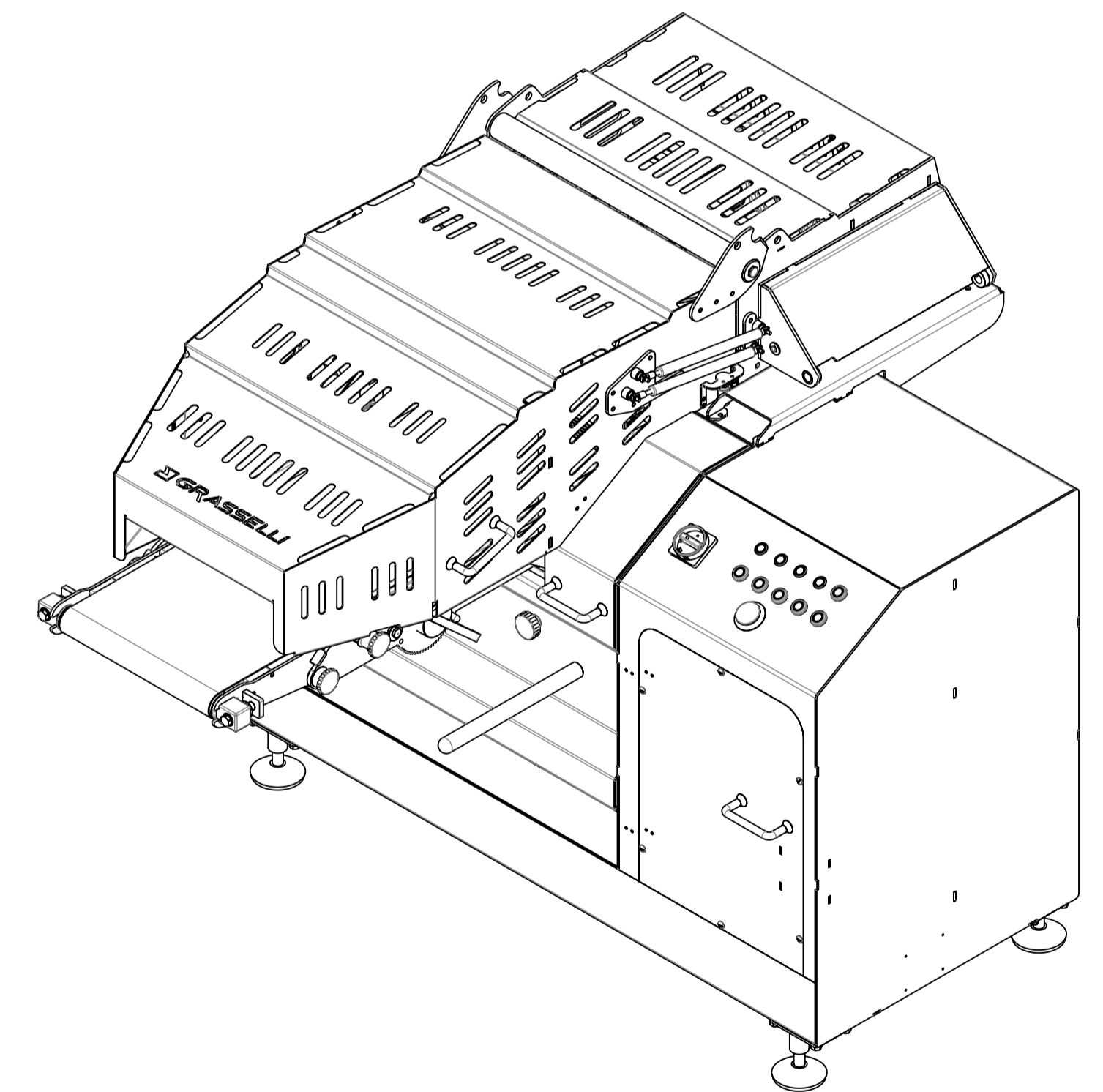
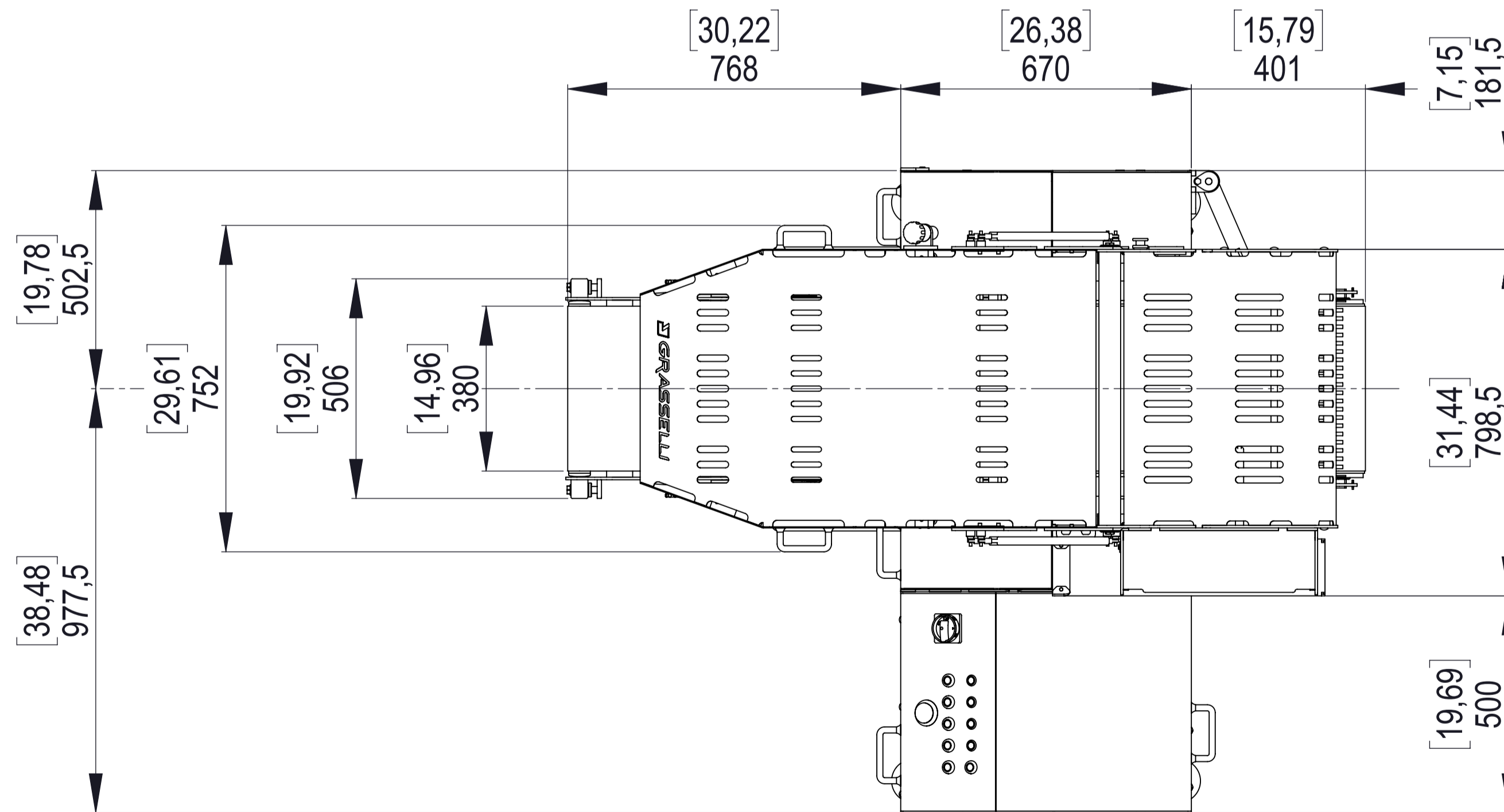

0	-	-	-
N°	Modifica	Data	Nome
Descrizione		Togliere bave e spigoli vivi	
HORIZONTAL SLICER MODEL KSL400		Macchina	
ASSIEME TAGLIAFETTINE ORIZZONTALE KSL400 MY 2017		KSL400	
Disegnatore		Codice	
L.Barozzi		KSL400 MY2017	
Materiale		Data	
-		16/02/2018	
Stato		Applicazione	
-		-	
Peso		Scala	
539.88 Kg		1:10	
www.grasselli.com		Nome File	