

GLOBALLY RAISING THE STANDARDS OF FOOD THROUGH THE ART OF SLICING

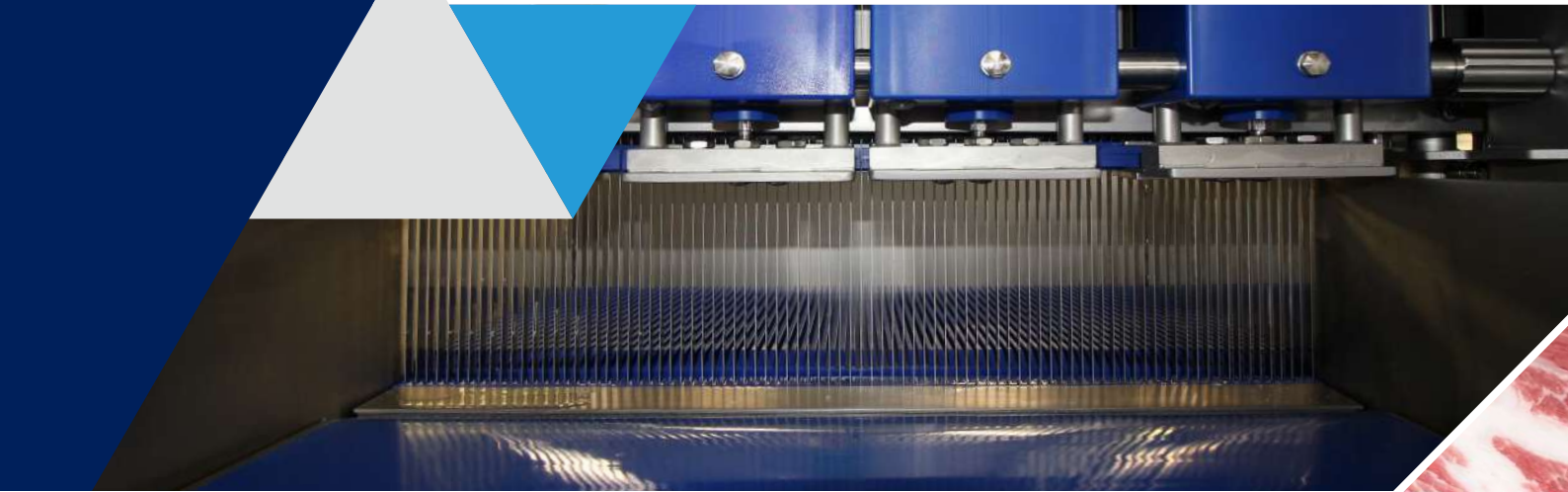

FSL

Semi-automatic vertical slicer



TAGLIAFETTINE VERTICALE SEMI-AUTOMATICA



FSL

Tagliafettine semi-automatica completamente lavabile anche internamente.

Soluzione per la lavorazione della carne fresca estremamente versatile, grazie all'impianto elettrico esterno che rende più agevole l'accesso per la pulizia.

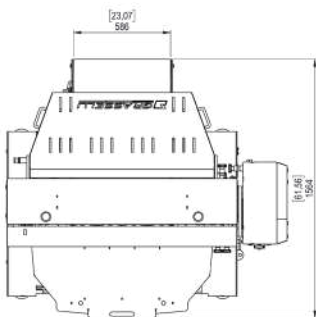
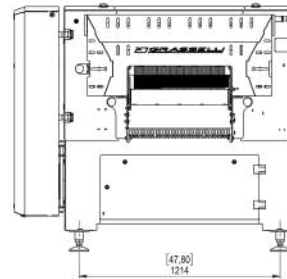
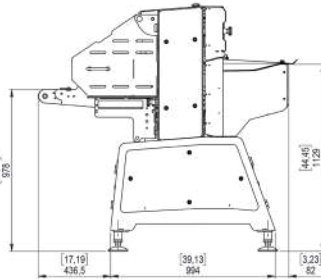
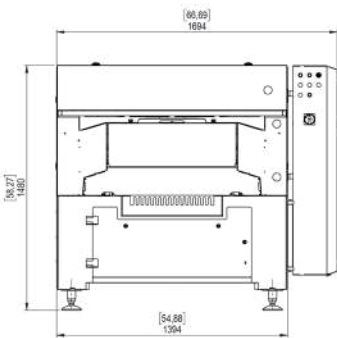

*Layout: FSL 600

Dati Tecnici

	FSL 600	FSL 600 YC	FSL 1000
Height	1480 mm / 58.27"	1436 mm / 56.55"	1494 mm / 58.84"
Width	1694 mm / 66.69"	1979 mm / 77.91"	2093 mm / 82.40"
Depth	1564 mm / 61.56"	1793.3 mm / 68.48"	1583 mm / 62.3"
Weight	800 Kg - 1763 lb	/	1270 Kg / 2800 lb
Motor Power	4.2 Kw / 5.5 Kw	4.2 Kw / 5.5 Kw	5.5 Kw
Noise Level	68 db	68 db	68 db
Maximum working width	586 mm / 23.07"	610 mm / 24.01"	1000 mm / 39.40"
Operator control circuit	24V	24V	24V
Minimum slicing pitch bone-in	10 mm / 0.39"	10 mm / 0.39"	10 mm / 0.39"
Minimum slicing pitch boneless	2.5 mm / 0.09"	2.5 mm / 0.12"	5 mm / 0.19"
Air consumption	30 l/min	30 l/min	30 l/min

**1. Completamente igienizzabile**

Pensata per garantire una perfetta sanificazione sia interna che esterna, tutti i componenti sono dotati del grado di protezione IP69K e possono essere lavati con acqua ad alta pressione.

**2. Risparmia tempo nelle regolazioni meccaniche**

Sistema di cambio rapido lame opzionale per sostituire l'intero set di lame in pochi minuti, facilitato anche dal sistema di tensionamento delle lame automatizzato.

**3. Estremamente adattabile per il massimo delle prestazioni**

Con una vasta gamma di opzioni di taglio, i parametri di taglio FSL possono essere regolati per consentire la quantità massima del prodotto tagliato.

**4. Produttività comprovata sul campo**

FSL ha dimostrato di poter ottenere una capacità di taglio fino a 2.000Kg/h in base alle condizioni del prodotto.

**5. Soluzioni speciali disponibili su richiesta**

La camera di taglio può essere realizzata su misura per andare incontro alle specifiche caratteristiche del prodotto, ad esempio con spessori di taglio differenziati.

**6. Modello YC disponibile**

FSL può essere dotata di Pusher personalizzati, progettati per adattarsi alla forma e alla posizione di caricamento, con lo scopo di ottenere un risultato finale di fette precise raggruppate in base all'aspetto originale del prodotto.

**7. Opzione BI**

Versione BI disponibile per prodotti con osso, con un sistema di pressatura prodotto frazionato.

**8. Facile sanificazione senza utensili.**

Ottieni una sanificazione perfetta, senza utensili necessari sia per le operazioni di lavaggio che di sostituzione delle lame.

**9. Costruzione solida**

Il telaio della macchina è costruito in acciaio inox controllato e certificato non radioattivo per assicurare un'igienizzazione superiore e maggiore longevità.



Follow Us

SEMI-AUTOMATIC VERTICAL SLICER



FSL

Semi-automatic slicer, completely washable also internally.

Extremely versatile solution for the processing of fresh meat, thanks to the external electrical system that makes it easier to access the components for cleaning.

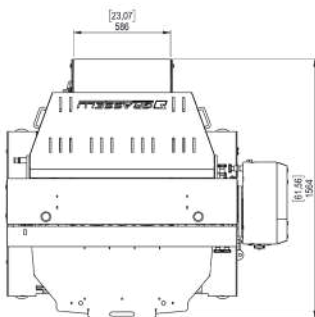
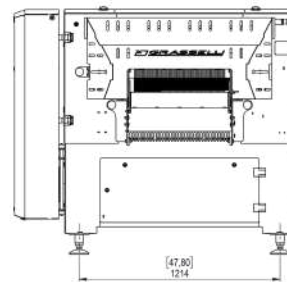
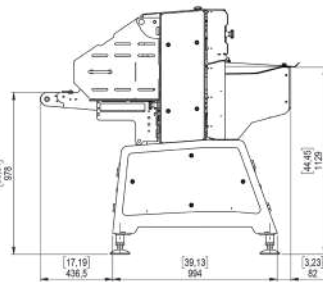
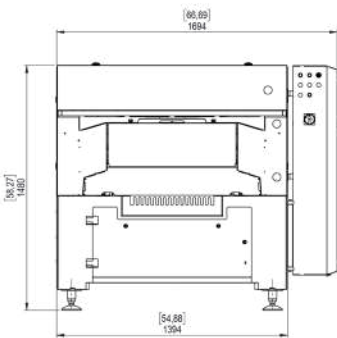

*Layout: FSL 600

Technical Data

	FSL 600	FSL 600 YC	FSL 1000
Height	1480 mm / 58.27"	1436 mm / 56.55"	1494 mm / 58.84"
Width	1694 mm / 66.69"	1979 mm / 77.91"	2093 mm / 82.40"
Depth	1564 mm / 61.56"	1793.3 mm / 68.48"	1583 mm / 62.3"
Weight	800 Kg - 1763 lb	/	1270 Kg / 2800 lb
Motor Power	4.2 Kw / 5.5 Kw	4.2 Kw / 5.5 Kw	5.5 Kw
Noise Level	68 db	68 db	68 db
Maximum working width	586 mm / 23.07"	610 mm / 24.01"	1000 mm / 39.40"
Operator control circuit	24V	24V	24V
Minimum slicing pitch bone-in	10 mm / 0.39"	10 mm / 0.39"	10 mm / 0.39"
Minimum slicing pitch boneless	2.5 mm / 0.09"	2.5 mm / 0.12"	5 mm / 0.19"
Air consumption	30 l/min	30 l/min	30 l/min



1. Ideal for a variety of applications

As the market standard vertical slicer with hundreds of machines sold worldwide, FSL is able to slice fresh, positive temperature products or crust frozen ones (up to -4/-5 degrees), both boneless and bone-in, with no chipping.



2. Save time on mechanical adjustments

Optional quick blade changing system for replacing the entire set of blades in just a few minutes, also made easier by the automated blade tension adjustment system.



3. Extremely adaptable for maximum performance

With a wide range of cutting options, FSL's cutting parameters can be adjusted to allow for the maximum quantity of product to be sliced.



4. Field proven productivity

FSL has proven to deliver a cutting capacity of up to 2.000 Kg/h depending on the product conditions.



5. Special solutions available on request

The cutting chamber can be tailored to meet the product's specific characteristics, e.g. with differentiated cutting thicknesses.



6. Through-pusher Option

FSL can be equipped with personalized through-pushers designed to match the product's shape and infeed position, in order to obtain an end-result of neat slices grouped according to the original appearance of the product.



7. BI Option

BI version available for bone-in products, with sectioned pressing system.



8. Easy sanitation without any tools

Get perfect, thorough sanitation with no tools needed for either the cleaning operations and blades replacement.



9. Robust construction

The machine frame is made of food-grade non-radioactive stainless steel, to ensure for superior hygiene and longevity.



ПОЛУАВТОМАТИЧЕСКАЯ ВЕРТИКАЛЬНАЯ ЛОМТЕРЕЗКА



FSL

Полуавтоматическая машина для нарезки ломтиков позволяет выполнить полную очистку, в том числе внутри.

Универсальное решение для обработки свежего мяса благодаря внешней электрической системе, облегчающей доступ для очистки компонентов.

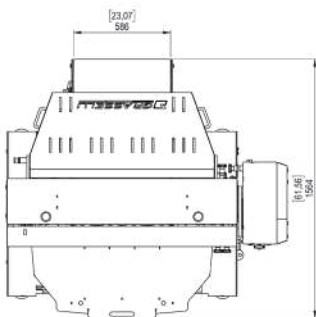
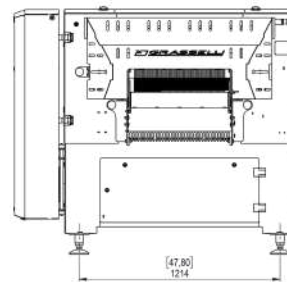
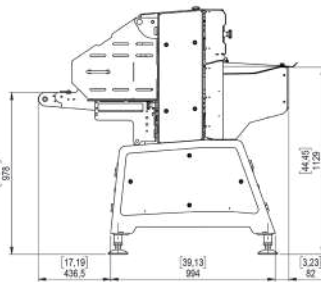
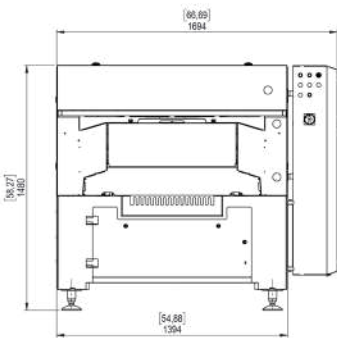

*Layout: FSL 600

Технические данные

	FSL 600	FSL 600 YC	FSL 1000
Height	1480 mm / 58.27"	1436 mm / 56.55"	1494 mm / 58.84"
Width	1694 mm / 66.69"	1979 mm / 77.91"	2093 mm / 82.40"
Depth	1564 mm / 61.56"	1793.3 mm / 68.48"	1583 mm / 62.3"
Weight	800 Kg - 1763 lb	/	1270 Kg / 2800 lb
Motor Power	4.2 Kw / 5.5 Kw	4.2 Kw / 5.5 Kw	5.5 Kw
Noise Level	68 db	68 db	68 db
Maximum working width	586 mm / 23.07"	610 mm / 24.01"	1000 mm / 39.40"
Operator control circuit	24V	24V	24V
Minimum slicing pitch bone-in	10 mm / 0.39"	10 mm / 0.39"	10 mm / 0.39"
Minimum slicing pitch boneless	2.5 mm / 0.09"	2.5 mm / 0.12"	5 mm / 0.19"
Air consumption	30 l/min	30 l/min	30 l/min

**1. Идеально подходит для различных видов применения**

Являясь стандартом на рынке вертикальных ломтерезок с сотнями машин, проданных по всему миру, FSL способна нарезать находящиеся при положительной температуре свежие или поверхностно замороженные (до -4 -5 градусов) продукты, как с костями, так и без костей без образования осколков.

**2. Экономия времени на механическую регулировку**

Опциональная система быстрой смены ножей для замены всего комплекта ножей за считанные минуты, облегчаемой также благодаря автоматизированной системе натяжения ножей.

**3. Чрезвычайно высокая адаптируемость для достижения максимальной производительности**

Благодаря широкому ассортименту опций резки параметры машины NSA могут быть отрегулированы для достижения максимального выхода нарезанного продукта.

**4. Проверенная на практике производительность**

FSL доказала, что она может достигать производительности резки до 2000 кг/ч в зависимости от состояния продукта.

**5. Специальные решения доступны по специальному заказу**

Камера резки может быть изготовлена на заказ в соответствии с конкретными характеристиками продукта, например, с различными толщинами резки.

**6. Опция проходного толкателя**

FSL может быть оснащен персонализированными толкателями, разработанными с учетом формы и положения загрузки, с целью достижения конечного результата в виде точно нарезанных ломтиков, сгруппированных в соответствии с первоначальным видом продукта.

**7. Исполнение VI**

Для продуктов с костями доступна версия VI с системой прессования фракционированного продукта.

**8. Простая дезинфекция без инструментов**

Воспользуйтесь возможностью идеальной дезинфекции без каких-либо инструментов как при мойке, так и при замене ножей.

**9. Надежная конструкция**

Станина машины изготовлена из проверенной и сертифицированной нерадиоактивной нержавеющей стали для повышения гигиеничности и увеличения срока службы.



CORTADORA VERTICAL SEMIAUTOMÁTICA



FSL

Fileteadora semiautomáticas íntegramente lavable, incluso también su interior.

Solución ideal para el procesamiento de carne fresca y extremadamente versátil gracias a la instalación eléctrica exterior que facilita el acceso a la máquina para realizar la limpieza de sus componentes.

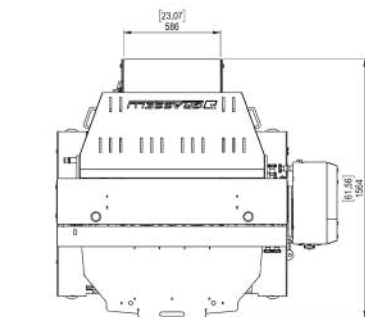
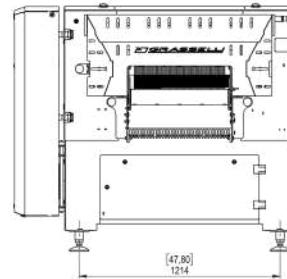
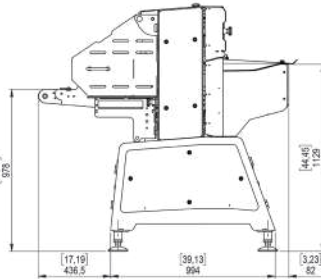
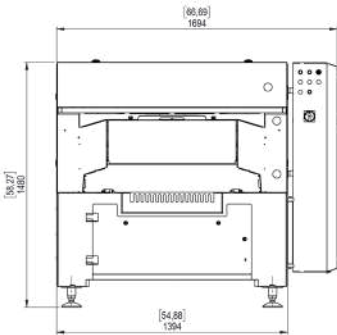

*Layout: FSL 600

Datos Técnicos

	FSL 600	FSL 600 YC	FSL 1000
Height	1480 mm / 58.27"	1436 mm / 56.55"	1494 mm / 58.84"
Width	1694 mm / 66.69"	1979 mm / 77.91"	2093 mm / 82.40"
Depth	1564 mm / 61.56"	1793.3 mm / 68.48"	1583 mm / 62.3"
Weight	800 Kg - 1763 lb	/	1270 Kg / 2800 lb
Motor Power	4.2 Kw / 5.5 Kw	4.2 Kw / 5.5 Kw	5.5 Kw
Noise Level	68 db	68 db	68 db
Maximum working width	586 mm / 23.07"	610 mm / 24.01"	1000 mm / 39.40"
Operator control circuit	24V	24V	24V
Minimum slicing pitch bone-in	10 mm / 0.39"	10 mm / 0.39"	10 mm / 0.39"
Minimum slicing pitch boneless	2.5 mm / 0.09"	2.5 mm / 0.12"	5 mm / 0.19"
Air consumption	30 l/min	30 l/min	30 l/min

**1. Ideal para múltiples aplicaciones**

La FSL es el estándar del mercado de cortadoras horizontales, con cientos de máquinas vendidas en todo el mundo y capaz de cortar productos frescos o cocidos, a temperatura positiva o congelados superficialmente (hasta -4 -5 grados), tanto con hueso como sin hueso, sin producir astillas.

**2. Ahorro de tiempo en los ajustes mecánicos**

Sistema opcional de cambio rápido de cuchillas para cambiar todo el kit de cuchillas en cuestión de minutos, facilitado también por el sistema automático de tensión de las cuchillas.

**3. Extremadamente adaptable para un máximo rendimiento**

Con una amplia variedad de opciones de corte, los parámetros de corte de la FSL pueden ajustarse para permitir la máxima cantidad de producto cortado.

**4. Productividad probada en el campo**

La FSL ha demostrado que puede alcanzar una capacidad de corte de hasta 2000 kg/h dependiendo de las condiciones del producto.

**5. Soluciones especiales disponibles como opcional**

La cámara de corte puede adaptarse a las características específicas del producto, por ejemplo, con grosores de corte diferenciados.

**6. Opción de empujador pasante**

La FSL puede equiparse con empujadores personalizados, diseñados para adaptarse a la forma y posición de la carga, con el objetivo de conseguir un resultado final de cortes precisos agrupados según el aspecto original del producto.

**7. Opción BI**

Versión BI disponible para productos con hueso, con un sistema de prensado del producto fraccionado.

**8. Fácil desinfección sin herramientas**

Obtenga una perfecta desinfección sin necesidad de herramientas tanto para el lavado como para el cambio de cuchillas.

**9. Construcción sólida**

El chasis de la máquina está construido con acero inoxidable no radiactivo, probado y certificado, para garantizar una higiene y una longevidad superiores.



HALBAUTOMATISCHE VERTIKALE SCHNEIDEMASCHINE



FSL

Halbautomatischer Scheibenschneider, auch innen vollständig zu reinigen.

Eine außerordentlich vielseitige Lösung für die Frischfleischverarbeitung, dank der externen elektrischen Ausrüstung, die einen vereinfachten Zugang zur Reinigung der Komponenten ermöglicht.

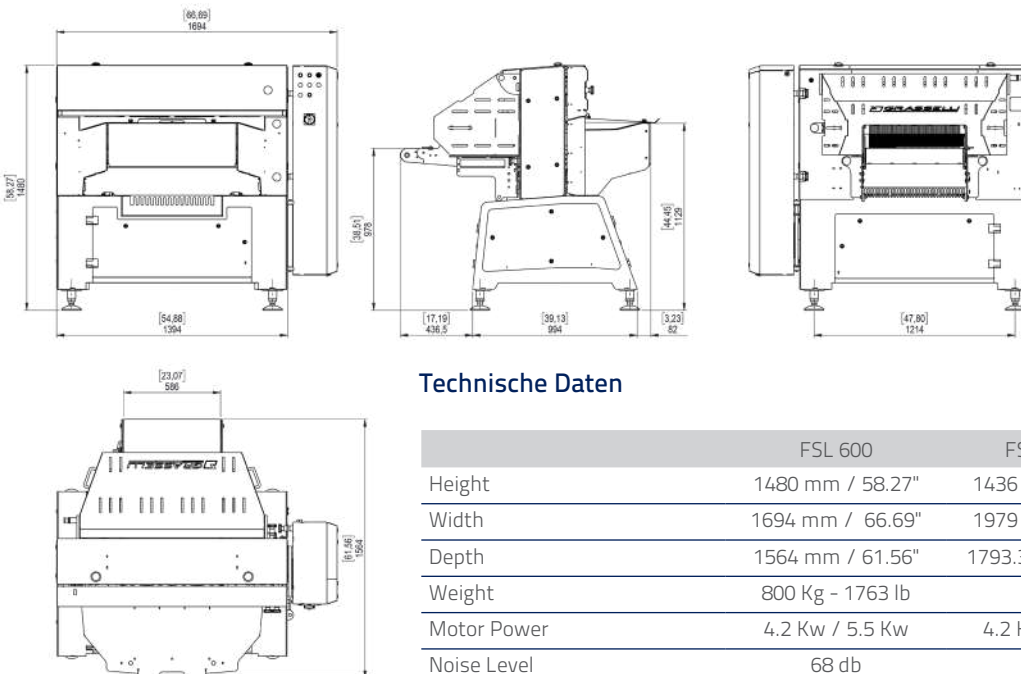

Technische Daten

	FSL 600	FSL 600 YC	FSL 1000
Height	1480 mm / 58.27"	1436 mm / 56.55"	1494 mm / 58.84"
Width	1694 mm / 66.69"	1979 mm / 77.91"	2093 mm / 82.40"
Depth	1564 mm / 61.56"	1793.3 mm / 68.48"	1583 mm / 62.3"
Weight	800 Kg - 1763 lb	/	1270 Kg / 2800 lb
Motor Power	4.2 Kw / 5.5 Kw	4.2 Kw / 5.5 Kw	5.5 Kw
Noise Level	68 db	68 db	68 db
Maximum working width	586 mm / 23.07"	610 mm / 24.01"	1000 mm / 39.40"
Operator control circuit	24V	24V	24V
Minimum slicing pitch bone-in	10 mm / 0.39"	10 mm / 0.39"	10 mm / 0.39"
Minimum slicing pitch boneless	2.5 mm / 0.09"	2.5 mm / 0.12"	5 mm / 0.19"
Air consumption	30 l/min	30 l/min	30 l/min

*Layout: FSL 600



1. Ideal für mehrere Anwendungen

Als Marktstandard bei Vertikalschneidern mit Hunderten von weltweit verkauften Maschinen ist FSL in der Lage, frische Produkte bei positiver Temperatur oder an der Oberfläche gefroren (bis zu -4 -5 Grad) zu schneiden, sowohl mit als auch ohne Knochen, ohne dass Splitter entstehen.



2. Spart Zeit bei mechanischen Einstellungen

Optionales Schnellwechselsystem für den Wechsel des gesamten Messersatzes in Minutenschnelle, das auch durch das automatische Messerspannsystem unterstützt wird.



3. Äußerst anpassungsfähig für maximale Leistung

Mit einer breiten Palette von Schneideoptionen können die FSL-Schneideparameter so eingestellt werden, dass die maximale Menge an geschnittenem Produkt erzielt wird.



4. Bewährte Produktivleistung in der Praxis

FSL hat bewiesen, dass es je nach Produktbedingungen eine Schneidleistung von bis zu 2.000 kg/h erreichen kann.



5. Sonderlösungen auf Anfrage erhältlich

Die Schneidkammer kann an spezifische Produkteigenschaften angepasst werden, z.B. mit unterschiedlichen Schnittstärken.



6. Option Durchlaufschieber

FSL kann mit kundenspezifischen Schiebern ausgestattet werden, die an die Form und Position des zugeführten Lebensmittel angepasst sind, mit dem Ziel, ein Endergebnis von präzisen Scheiben zu erzielen, die entsprechend dem ursprünglichen Aussehen des Produkts gruppiert sind.



7. BI-Option

BI-Version für Produkte mit Knochen erhältlich, mit einem fraktionierten Produktpresssystem.



8. Einfache Sanitisierung

Ohne Werkzeug Erzielen Sie eine perfekte Sanitisierung ohne Werkzeug, sowohl für die Reinigung als auch für den Klingenswechsel.



9. Solide Konstruktion

Das Gehäuse des Geräts ist aus geprüftem und zertifiziertem nicht radioaktivem Edelstahl gefertigt, um höchste Hygiene und Langlebigkeit zu gewährleisten.



Follow Us

COUPEUR VERTICAL SEMI-AUTOMATIQUE



FSL

Trancheuse semi-automatique complètement nettoyable, même à l'intérieur.

Solution pour la préparation de la viande fraîche extrêmement versatile, grâce à l'installation électrique externe facilitant l'accès pour le nettoyage des composants.

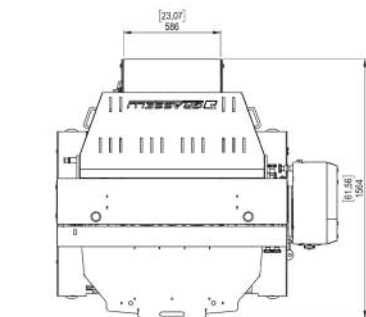
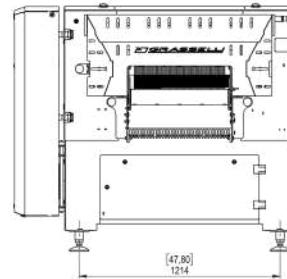
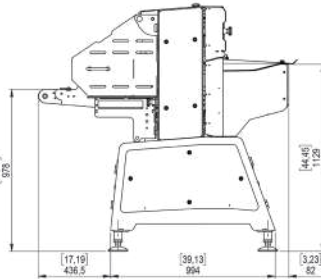
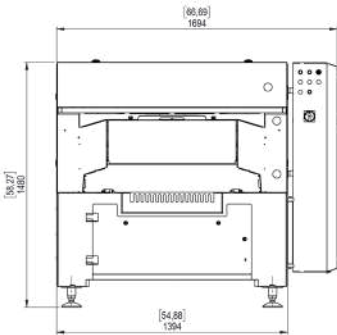

*Layout: FSL 600

Données techniques

	FSL 600	FSL 600 YC	FSL 1000
Height	1480 mm / 58.27"	1436 mm / 56.55"	1494 mm / 58.84"
Width	1694 mm / 66.69"	1979 mm / 77.91"	2093 mm / 82.40"
Depth	1564 mm / 61.56"	1793.3 mm / 68.48"	1583 mm / 62.3"
Weight	800 Kg - 1763 lb	/	1270 Kg / 2800 lb
Motor Power	4.2 Kw / 5.5 Kw	4.2 Kw / 5.5 Kw	5.5 Kw
Noise Level	68 db	68 db	68 db
Maximum working width	586 mm / 23.07"	610 mm / 24.01"	1000 mm / 39.40"
Operator control circuit	24V	24V	24V
Minimum slicing pitch bone-in	10 mm / 0.39"	10 mm / 0.39"	10 mm / 0.39"
Minimum slicing pitch boneless	2.5 mm / 0.09"	2.5 mm / 0.12"	5 mm / 0.19"
Air consumption	30 l/min	30 l/min	30 l/min

**1. Idéal pour de multiples applications**

La norme du marché en matière de coupeurs verticaux, avec des centaines de machines vendues dans le monde, FSL est capable de couper des produits frais à température positive ou surgelés (jusqu'à -4 -5 degrés), avec ou sans os, sans produire d'échardes.

**2. Gain de temps sur les réglages mécaniques**

Système de changement rapide des lames en option pour changer l'ensemble des lames en quelques minutes, également facilité par le système de tension automatique des lames.

**3. Extrêmement adaptable pour une performance maximale**

Grâce à une large gamme d'options de coupe, les paramètres de coupe du FSL peuvent être ajustés pour permettre une quantité maximale de produit coupé.

**4. Une productivité éprouvée sur le terrain**

FSL a prouvé qu'il pouvait atteindre une capacité de coupe allant jusqu'à 2 000 kg/h selon les conditions du produit.

**5. Solutions spéciales disponibles sur demande**

La chambre de coupe peut être personnalisée pour répondre à des caractéristiques de produit spécifiques, par exemple avec des épaisseurs de coupe différenciées.

**6. Option de poussoir à passage**

FSL peut être équipé de poussoirs personnalisés, conçus pour s'adapter à la forme et à la position du chargement, dans le but d'obtenir un résultat final de tranches précises regroupées selon l'aspect du produit original.

**7. Option BI**

Version BI disponible pour les produits avec os, avec un système de pressage des produits fractionnés.

**8. Assainissement facile, sans outils**

Obtenez un assainissement parfait sans aucun outil, tant pour le lavage que pour le remplacement des lames.

**9. Construction solide**

Le châssis de la machine est construit en acier inoxydable non radioactif testé et certifié pour garantir une hygiène et une longévité supérieures.



CORTADOR VERTICAL SEMI-AUTOMÁTICO



FSL

Fatiador semiautomático completamente lavável também internamente.

Solução para o processamento da carne fresca, extremamente versátil graças ao sistema elétrico externo que facilita o acesso para a limpeza dos componentes.

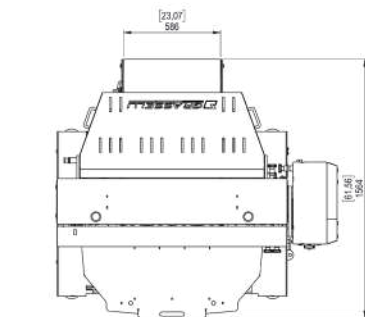
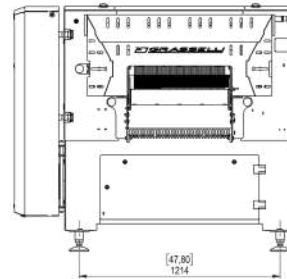
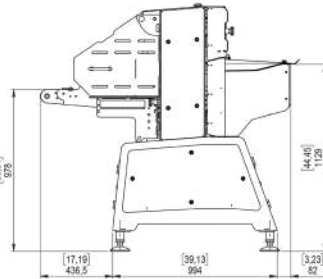
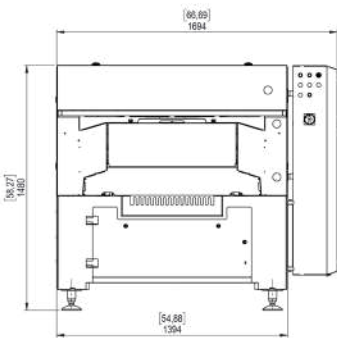

*Layout: FSL 600

Dados Técnicos

	FSL 600	FSL 600 YC	FSL 1000
Height	1480 mm / 58.27"	1436 mm / 56.55"	1494 mm / 58.84"
Width	1694 mm / 66.69"	1979 mm / 77.91"	2093 mm / 82.40"
Depth	1564 mm / 61.56"	1793.3 mm / 68.48"	1583 mm / 62.3"
Weight	800 Kg - 1763 lb	/	1270 Kg / 2800 lb
Motor Power	4.2 Kw / 5.5 Kw	4.2 Kw / 5.5 Kw	5.5 Kw
Noise Level	68 db	68 db	68 db
Maximum working width	586 mm / 23.07"	610 mm / 24.01"	1000 mm / 39.40"
Operator control circuit	24V	24V	24V
Minimum slicing pitch bone-in	10 mm / 0.39"	10 mm / 0.39"	10 mm / 0.39"
Minimum slicing pitch boneless	2.5 mm / 0.09"	2.5 mm / 0.12"	5 mm / 0.19"
Air consumption	30 l/min	30 l/min	30 l/min

**1. Ideal para múltiplas aplicações**

O padrão de mercado em cortadores verticais com centenas de máquinas vendidas em todo o mundo, FSL é capaz de cortar produtos frescos a temperatura positiva ou congelados à superfície (até -4 -5 graus), tanto com ou sem osso, sem a produção de lascas.

**2. Poupe tempo nos ajustes mecânicos**

Sistema opcional de troca rápida de lâminas para mudar todo o conjunto de lâminas em poucos minutos, também facilitado pelo sistema automatizado de tensionamento de lâminas.

**3. Extremamente adaptável para o máximo desempenho**

Com uma vasta gama de opções de corte, os parâmetros de corte FSL podem ser ajustados para permitir a quantidade máxima de produto cortado.

**4. Produtividade comprovada no terreno**

A FSL provou que pode atingir uma capacidade de corte de até 2.000 kg/h, dependendo das condições do produto.

**5. Soluções especiais disponíveis a pedido**

A câmara de corte pode ser personalizada para satisfazer características específicas do produto, por exemplo, com espessuras de corte diferenciadas.

**6. Opção de alimentação por empurrador**

A FSL pode ser equipada com empurradores personalizados, concebidos para se adaptarem à forma e posição do carregamento, com o objetivo de alcançar um resultado final de fatias precisas agrupadas de acordo com a aparência do produto original.

**7. Opção BI**

Versão BI disponível para produtos com osso, com um sistema de prensagem fracionada do produto.

**8. De fácil higienização sem utensílios**

Obtém-se uma higienização perfeita sem qualquer utensílio necessário tanto para a lavagem como para a substituição das lâminas.

**9. Construção sólida**

O chassis da máquina é construído em aço inoxidável não radioativo testado e certificado para assegurar uma higiene superior e longevidade.



Follow Us

半自动纵向切片机



FSL

半自动切片机内部也可实现完全清洗。

外部电子系统的安装使得清洁组件更加容易, 为新鲜肉类加工提供万能的设备。

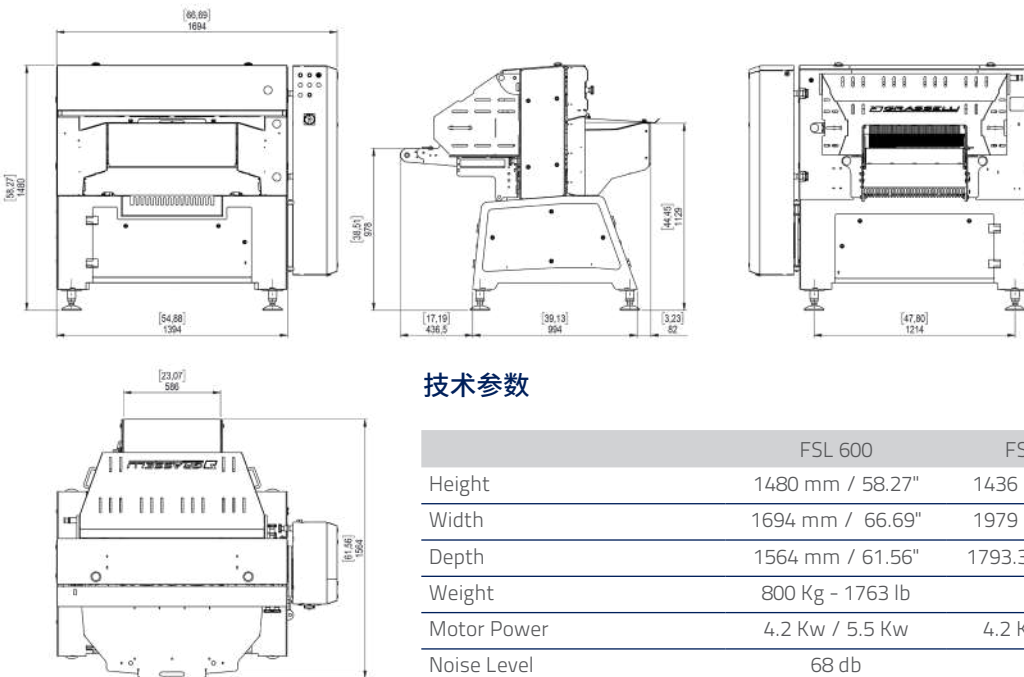

技术参数

	FSL 600	FSL 600 YC	FSL 1000
Height	1480 mm / 58.27"	1436 mm / 56.55"	1494 mm / 58.84"
Width	1694 mm / 66.69"	1979 mm / 77.91"	2093 mm / 82.40"
Depth	1564 mm / 61.56"	1793.3 mm / 68.48"	1583 mm / 62.3"
Weight	800 Kg - 1763 lb	/	1270 Kg / 2800 lb
Motor Power	4.2 Kw / 5.5 Kw	4.2 Kw / 5.5 Kw	5.5 Kw
Noise Level	68 db	68 db	68 db
Maximum working width	586 mm / 23.07"	610 mm / 24.01"	1000 mm / 39.40"
Operator control circuit	24V	24V	24V
Minimum slicing pitch bone-in	10 mm / 0.39"	10 mm / 0.39"	10 mm / 0.39"
Minimum slicing pitch boneless	2.5 mm / 0.09"	2.5 mm / 0.12"	5 mm / 0.19"
Air consumption	30 l/min	30 l/min	30 l/min

*Layout: FSL 600



1. 多种应用的理想方案

构成纵向切片机的市场标准，已在全球销售数百台机器，FSL 切片机能够切割常温或表面冻结的新鲜产品（低至 -4/-5 度），无论带骨肉还是无骨肉，都不会产生碎骨渣。



2. 节省机械调整时间

可选快速更换刀具系统，由刀具自动张紧系统协助，在几分钟内完成整套刀具的更换。



3. 极易调整, 可实现极佳结果

FSL 切片机具有多种切割选项，能通过调整切割参数以实现最大的产品切割量。



4. 生产效率现场已验证

FSL 切片机已证明，根据产品的条件，切割速率可高达 2000 公斤/小时。



5. 可根据要求提供特殊方案

切割室可以定制，以满足产品的具体特性，例如不同的切割厚度。



6. 通过推杆选项

FSL 切片机可配备定制推杆，旨在适应形状和加载位置，以根据产品原外观分组获得精确切片的最终结果。



7. BI 选项

BI 版本可用于带骨肉，具有分离后的产品压制系统。



8. 轻松消毒, 无需工具

实现完美消毒，清洗和更换刀片操作均无需工具。



9. 坚固的结构

机器框架采用经过检验和认证的非放射性不锈钢制成，确保更高的卫生条件和更长的使用寿命。



